

УДК 666.3

ENZYM FARMING – BRINGING GREEN AND SAFETY TO FARMLAND

孙鹏舒 (Sun PengShu), 王钦 (Wang Qin), 王亚顶 (Wang Yading), 赵梓翔 (Zhao Zixiang),
王媛 (Wang Yuan)

东北大学 (Northeastern University)

e-mail: 635293234@qq.com

Summary. *Garbage enzymes rationally using of waste from fruits and vegetables are rich in nutritionally active substances and microbial groups and positively affect the growth of agricultural crops. In this project, by studying the effect of different classes of garbage enzymes on plant growth at different concentrations, and study on molecular biological mechanism will provide sufficient theoretical support for the development of environmental friendly irrigation machine in agriculture.*

In recent years, with the increasing awareness of environmental protection, eco-friendly production methods are gradually being more emphasized, and people are paying increasing concentration on pollution-free and safe food. Garbage Enzyme is obtained by fermenting fruit and vegetable waste, water and sugar in a certain ratio for 3 months with a variety of microorganisms such as yeast, E. coli, lactic acid bacteria, acetic acid bacteria, actinomycetes and copper-craving bacteria. Garbage Enzyme is a natural, non-polluting and safe alternative to pesticides in agriculture. Enzymes can help reduce pesticide residues in crops and improve crop quality. Applying enzymes to soil and crops as a kind of bio-organic fertilizer can improve soil fertility, eliminate environmental pollutants, promote the absorption and use of nutrients by plants, improve resource utilization and crop quality, significantly increase crop yields and improve fruit quality. It improves fruit quality and makes a great contribution to the improvement of agricultural productivity. The study of the effect of Garbage Enzyme on crop quality improvement is an important guide to the application of Garbage Enzyme as an enzyme fertilizer in agricultural production. By replacing pesticides, Garbage Enzyme can greatly protect the ecological environment of agricultural production, ensure the safety of people's tongue and achieve ecological sustainability.

This project aims to improve crops by using Garbage Enzyme as a kind of bio-organic fertilizer. By measuring (1) the effects of different types and dilution gradients of Garbage Enzyme on the growth of crops; (2) the effects of different types and dilution gradients of Garbage Enzyme on the morphology, photosynthesis intensity, nutrient content and metabolism of different crops. It is acknowledged that this project can provide sufficient theoretical support for the subsequent development of the Garbage Enzyme Fermentation and Irrigation System for agricultural applications.

This project uses waste of various fruits and vegetables as raw materials and obtains different kinds of environmental protection enzymes through fermentation, and uses them to water various crops with different kinds and dilution gradients, expecting to obtain the most suitable enzyme types and dilution gradients of different crops. The specific experiments were divided into the following stages.

1. Selection of different types of fruit and vegetable waste and preparation of enzymes from them.
2. Selection and sowing of experimental crops, spraying with different enzymes at different dilution gradients, and setting up a control group.
3. Crop growth status measurements including plant height, stem thickness, leaf width and area as well as photosynthetic rate every 7 days.
4. Roots were sampled from each group every 30 days to analyse root growth patterns using WinRhizo and the remainder was frozen and preserved.
5. After the crop has matured, indicators such as nutrient content and key enzyme content of frozen samples are measured and compared with the corresponding control group.
6. Using Prism to analysis the most suitable Garbage Enzyme type and concentration gradient for each crop.

R&D Innovation:

1. Introducing for the first time the idea that enzymes made from different types of fruit and vegetable waste have different effects on crops.
2. First introduction of the determination of key enzyme levels and activities in crops at different stages of growth.
3. With a large variety of crops as the subject of analysis, the experimental base is large and it is easier to conclude the biological mechanism of crop growth promotion with Garbage Enzyme sprayed.
4. Combining experimental data with actual production to achieve a holistic approach to basic theory research, engineering and quantitative production.

Technology transformation:

According to the preliminary results of the experiment, a high level academic paper has been submitted; for green agriculture and ecological protection and can match the most suitable Garbage Enzyme spraying concentration gradient for a large number of crops derived from this project, an Garbage Enzyme fermentation and irrigation all-in-one machine (as shown in fig. 1 and fig. 2) has been designed and is under patent application, the user can put in raw materials to automatically ferment Garbage Enzyme, the user can place this device in front of the watering pipe.

The device can automatically configure the watering water according to the crop selected by the user, the watering method and the growing period of the crop, the user can also add the substance that needs to be irrigated in proportion when irrigating, in order to cope with the shortage of Garbage Enzyme when the user irrigates a large area.

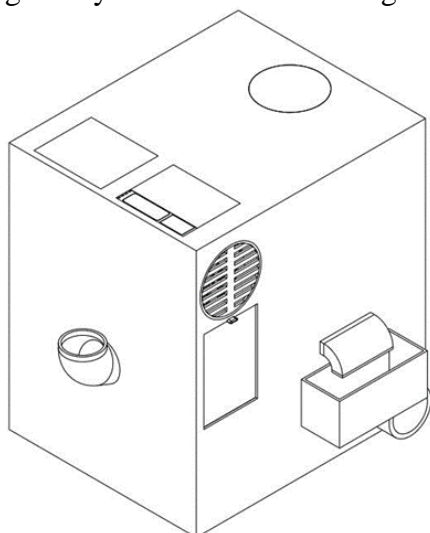

Figure 1 – Garbage Enzyme Fermentation and Irrigation Integrated Machine

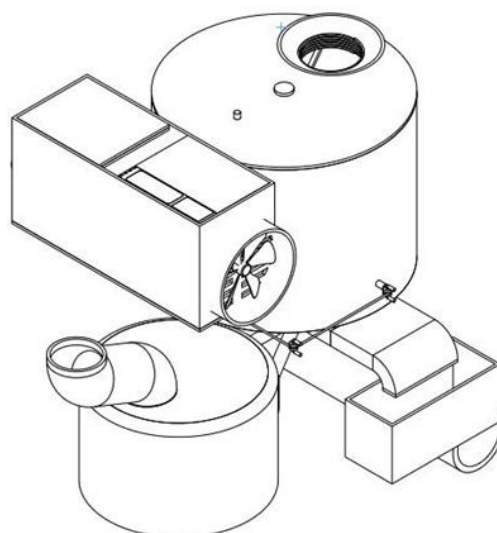

Figure 2 – Main body of Garbage Enzyme Fermentation and Irrigation Machine

УДК 666.3

废旧动力电池中有色金属的创新回收方法

谢瀚文(Xie Hanwen), 高旭成(Gao Xvcheng), 马继一(Ma Jiyi), 张万里(Zhang Wanli), 付宁(Fu Ning)

东北大学(Northeastern University)

e-mail: 1391033457@qq.com

Summary. This paper explains the team's research and development of a new vertical eddy current sorting machine, which solves the problem of high pollution and high emission that cannot process small-size electronic waste, can only sort non-metals and metals, and cannot separate different metals at the same time. It is a kind of mechanical and physical equipment that can realize the separation between small non-metals and metals and different metals.

According to the “New Energy Vehicle Industry Development Plan (2021–2035)” issued by the General Office of the State Council, China will vigorously develop new energy vehicles in the