

1. Introducing for the first time the idea that enzymes made from different types of fruit and vegetable waste have different effects on crops.
2. First introduction of the determination of key enzyme levels and activities in crops at different stages of growth.
3. With a large variety of crops as the subject of analysis, the experimental base is large and it is easier to conclude the biological mechanism of crop growth promotion with Garbage Enzyme sprayed.
4. Combining experimental data with actual production to achieve a holistic approach to basic theory research, engineering and quantitative production.

Technology transformation:

According to the preliminary results of the experiment, a high level academic paper has been submitted; for green agriculture and ecological protection and can match the most suitable Garbage Enzyme spraying concentration gradient for a large number of crops derived from this project, an Garbage Enzyme fermentation and irrigation all-in-one machine (as shown in fig. 1 and fig. 2) has been designed and is under patent application, the user can put in raw materials to automatically ferment Garbage Enzyme, the user can place this device in front of the watering pipe.

The device can automatically configure the watering water according to the crop selected by the user, the watering method and the growing period of the crop, the user can also add the substance that needs to be irrigated in proportion when irrigating, in order to cope with the shortage of Garbage Enzyme when the user irrigates a large area.

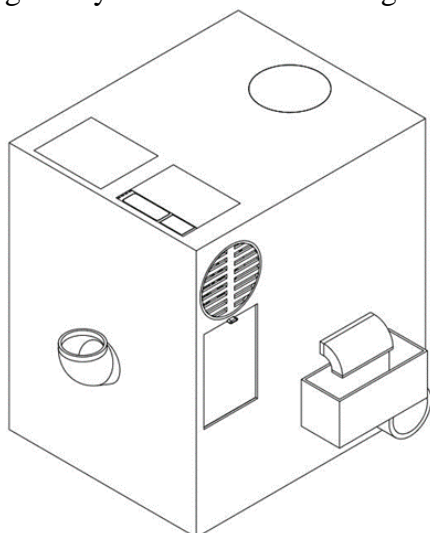

Figure 1 – Garbage Enzyme Fermentation and Irrigation Integrated Machine

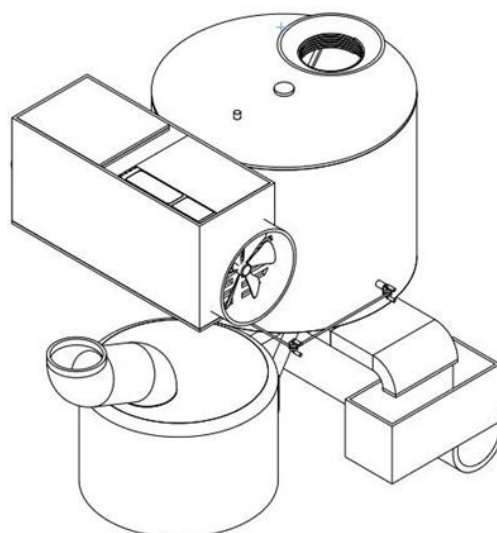

Figure 2 – Main body of Garbage Enzyme Fermentation and Irrigation Machine

УДК 666.3

废旧动力电池中有色金属的创新回收方法

谢瀚文 (Xie Hanwen), 高旭成 (Gao Xucheng), 马继一 (Ma Jiyi), 张万里 (Zhang Wanli), 付宁 (Fu Ning)

东北大学 (Northeastern University)

e-mail: 1391033457@qq.com

Summary. This paper explains the team's research and development of a new vertical eddy current sorting machine, which solves the problem of high pollution and high emission that cannot process small-size electronic waste, can only sort non-metals and metals, and cannot separate different metals at the same time. It is a kind of mechanical and physical equipment that can realize the separation between small non-metals and metals and different metals.

According to the “New Energy Vehicle Industry Development Plan (2021–2035)” issued by the General Office of the State Council, China will vigorously develop new energy vehicles in the

future, and it is expected that by 2025, China's new energy vehicle sales will reach 5 million, accounting for 20 % of new car sales and 44 % of the global new energy vehicle market capacity.

The vigorous promotion of new energy vehicles has led to the explosive growth of the power battery industry, and lithium iron phosphate batteries (LFPBs) occupy a large share in the power battery market because of their advantages of high safety, long cycle life and low price. Among the power batteries that have entered the scrap period in China, lithium iron phosphate batteries account for more than 70 %, so the recycling of waste lithium iron phosphate batteries is particularly important.

Regularly mixed materials, copper and aluminum pellets of different particle sizes.

The recycling process of waste power batteries in this project is: waste battery discharge – electrolyte collection – freezing crushing – winnowing (crushed materials and other powders) – magnetic separation (magnetic metals such as iron, cobalt and nickel) – vertical eddy current separation (copper and aluminum non-ferrous metals).

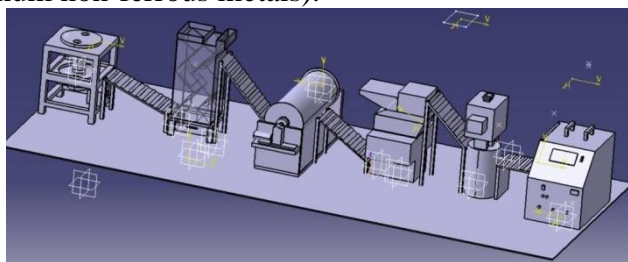

Figure 1 – Ideal process 3D printing model drawing. From right to left, there are discharge devices, electrolyte collection devices, crushers, magnetic separators, winnowing machines, and vertical eddy current sorters

First, the waste power battery is routinely discharged and the electrolyte is collected, and then frozen and crushed. We use liquid nitrogen to cool down the waste power battery, and use the brittle fracture temperature difference of the solid waste at low temperature to make the material brittle, and then crush. After freezing and crushing, winnowing can effectively separate metal and non-metallic materials and improve the degree of dissociation of waste power batteries. Then there is the conventional magnetic separation, which separates magnetic metals such as iron, cobalt and nickel. Finally, eddy current sorting is carried out by a vertical eddy current sorter.

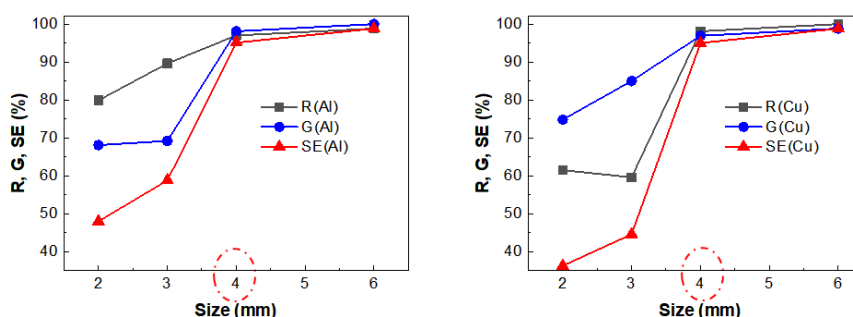

Figure 2 – Sorting results. R is for recovery G for recycling grade SE for sorting efficiency

From the preliminary experimental results in the figure above, it can be seen that the vertical eddy current sorting machine we designed can achieve 95 % sorting efficiency for materials with a particle size of more than 4 mm, and also has a certain sorting capacity for materials with a very small particle size below 4 mm. It improves the shortcomings of the previous sorting machine for the poor sorting efficiency of particle size materials below 5 mm, and can be applied to the sorting of waste battery materials with higher precision requirements.

The recycling process is energy-saving and environmentally friendly:

Compared to conventional processes, innovations include freeze crushing, winnowing and vertical eddy current sorters.

Freeze crushing technology crushes solid waste, uses liquid nitrogen to cool down the waste power battery, uses the brittle fracture temperature difference of solid waste at low temperature to make the material brittle, and then crushing, not only good crushing effect, improve conductivity, increase induction current, conducive to subsequent eddy current sorting, and also has excellent effects in energy saving and noise reduction: the driving force required is about 1/4 of the crushing at room temperature, the noise is reduced by about 7 dB, and the vibration is reduced by 1/5–1/4.

Eddy current sorter innovation:

Automatic control device: a sensor is set under the magnetic roller to sense the working status and temperature of the magnetic roller, and is controlled by the network control system. Prevents dangerous situations such as overheating and short-circuit temperature differences.

Low cost and long service life: the core magnetic roller material is reduced, the conveyor belt is eliminated, the cost is reduced, and the loss of the device is reduced and the service life is more than doubled.

Solve technical problems such as stickiness: optimize the feeding system and the improvement of the sorting structure, eliminate the sticky material and material leakage problems when feeding the conveyor belt, 100 % feeding, and avoid the collision problem in the sorting process.

Safety and environmental protection: using mechanical and physical methods, compared with chemical reagents, the danger is low, the waste is less and the environmental pollution is small.

High sorting rate and small footprint: Compared with the traditional eddy current sorting device, which can generally reach 30–50 % when sorting metal particles below 5mm, the primary sorting rate of metal particles below 5mm can reach more than 90 % after the optimization of the structure of this device, which greatly improves the sorting rate. It is reduced by about 75 % and is easy to carry.

УДК 666.3

REVIEW OF FERRITE RADAR ABSORBING METAMATERIALS

余欣燃 (Xinran Yu)

东北大学 (Northeastern University)

e-mail: xinran.yu.chn@gmail.com

Summary. Ferrite absorbing metamaterials designed with metamaterial structures can effectively broaden the absorption bandwidth of electromagnetic waves. The current mainstream approach is to compound ferrite with other materials to produce ferrite absorbing metamaterials with better performance.

Conventional ferrite wave-absorbing materials will undergo polarization rotation of reflected waves under longitudinal magnetization due to Faraday rotation effect, and will only absorb electromagnetic waves of a certain polarization under transverse magnetization [1]. Nowadays, ferrite absorbing metamaterials designed with metamaterial structures can effectively broaden the absorption bandwidth of electromagnetic waves. The current mainstream approach is to compound ferrite with other materials to produce ferrite absorbing metamaterials with better performance.

With the in-depth research related to ferromagnetic composite, the structure of ferrite and metal wire/stick composite has become a hot topic of research. 2001, Dewar [2] University of North Dakota, USA, first proposed to prepare wave-absorbing metamaterials by embedding periodically arranged metal sheets or metal wires directly into the ferromagnetic matrix. 2006, A. L. Adenot-Engelvin, P. Toneguzzo et al [3] studied the structure and outlined the basic topology on the laminate by metal wires as shown in fig. 1, which shows the strong anisotropy of the structure, fig. 1 shows the microwave permeability of the laminated composite using a 1 m thick CoFeSiB film deposited on a 23 m PET substrate (ferromagnetic volume fraction of 7 %), fig. 1 shows a sketch of the wire composite, and fig. 1 shows the microwave permeability of this composite with a ferromagnetic volume fraction of 7 %; after this Ji Zhou, Ke Bi et al [4] conducted an in-depth study of ferrite and metal wire/rod composite metamaterials, and experimentally demonstrated that a periodi-