

S., Some aspects for solving the energy balance equation of electric arcs in low-temperature plasma generator, Journal "IMK-14, Research and development", year X, No 18-19, 1-2/2004, pp. 15-18, 3. Colt J., Matters of the fourth state, Cutting technology, American machinist's, september/october 2002, 4. Colt J., How to compare plasma cutting costs, Forming & Fabricating-4/2002, pp. 27-31, 5. Plasma arc cutting – process and equipment considerations, TWI information, 6. Schwarz H., Rudaz A., Plasma: a welding and cutting technique with a future, www.psweld.com, 7. Plasma cutting history, www.hypertherm.com.

UDK 621.791.947.55

Miroslav R. Radovanovic

CUTTING PROCESS OF THE FUTURE

*University of Nis, Faculty of mechanical engineering
Nis, Serbia and Montenegro*

INTRODUCTION

Abrasive water jet cutting has become a highly developed industry technology. Its development has been favored by the fact that abrasive water jet cutting can be used in practically all areas in which solids are processed – stone, glass, plastics, composite materials and metals. Abrasive water jet technology was first introduced in 1984. The technique uses a mix of water and a fine abrasive for cutting hard materials. Mix abrasives with high pressure water give an effective tool to cut metals and nonmetals materials. Abrasive water jet cutting is the most suitable process for very thick, highly reflective or highly thermal-conductive materials, laminates and composite materials, as well as hard synthetics. The abrasive stream produces a kerf width that is ideal for cutting titanium, armor plate, steel, granite, composites, glass and many other materials. The list includes metals such as aluminium, carbon steel, stainless steel and high nickel alloys, or brittle materials such as marble, reinforced composites, and sandwiched materials. Abrasive water jet can cut a wide range of thickness. Typical thickness are 100 mm for stainless steel, 120 mm for aluminium, 140 mm for stone, 100 mm for glass, but not limited. Abrasive water jet cutting is of great interest for various reasons. Almost any material can be cut. The abrasive water jet makes it possible to cut random contours, very fine tabs and filigree structures. Abrasive water jet cutting is a very precise technique. Tolerances of ± 0.1 mm can be realized in metal cutting. The workpiece is not heat-stressed. Materials cut by abrasive water jet have a smooth, satin-like finish, similar to a fine sandblasted finish. Abrasive water jet cut material at room temperatures. As a result, there are no heat-

affected areas or structural changes in materials. Abrasive water jet can cut hardened metals and materials with low melting points. No heavy burrs are produced by the abrasive water jet. Parts can often be used directly without deburring. Those parts which do require further processing are easier to machine and finish. Abrasive water jet cutting is used in many industries, including the automobile, aerospace, and glass industries, to create precision parts from hard-to-cut materials.

ABRASIVE WATER JET CUTTING

By abrasive water jet cutting the high pressure pump produces the required pressure up to 400 MPa. A high pressure supply line direct the pressurized water from the pump to the cutting head. The high pressure supply line is terminated by a nozzle at which the pressure is relieved. A sapphire or ruby nozzle has a diameter of approx. 0.08 to 0.50 mm. The water pressure is relieved in the nozzle and a water jet is created. The water is pressed out of the nozzle at a speed of approx. 900 m/s – nearly three times the speed of sound. The result is a very thin, extremely high velocity water jet. Solid abrasive particles are added and mixed with the water jet and subsequently focused by a second nozzle – the abrasive nozzle. In figure 1 is shown abrasive water jet cutting.

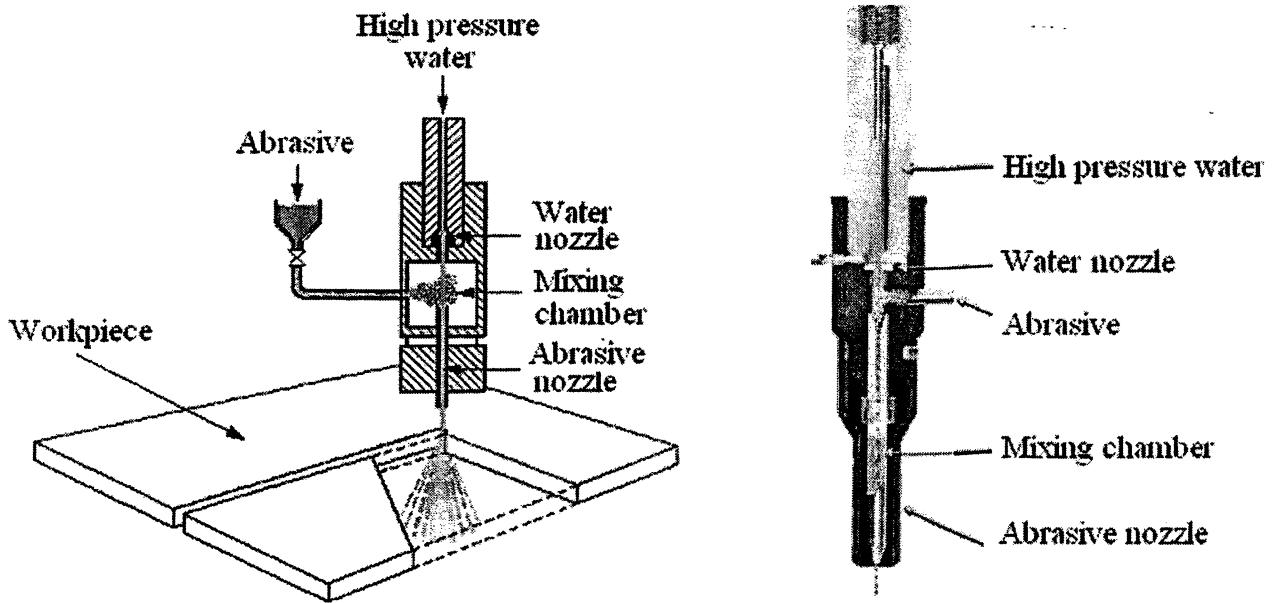

Figure 1. Abrasive water jet cutting

The high speed of the water jet creates a partial vacuum in the mixing chamber so that abrasive material and air are sucked in and flushed away by the water jet. This is known as the injector principle. The abrasive nozzle has two functions: it accelerates the abrasive particles and it focuses the jet. The cutting head makes a circular or

pendular motion over the piercing point. The abrasive water jet penetrates the material and progressively cuts the material guided by the cutting head along programmed contour. Abrasive water jet stream is the cutting tool. The cutting process is like grinding, except that abrasives are moved through the material by water rather than by a solid wheel. Most abrasive water jet cutting theories explain abrasive water jet cutting as a form of micro erosion. Abrasive water jet's effect upon a workpiece material can be divided into several characteristic phases:

- The abrasive water jet works itself slowly into material. In the process of cutting, the abrasive water jet moves along the workpiece at a constant feed rate. The angle between the undisturbed abrasive water jet and the front edge constantly increases. As a result is also deflected away from the cutting direction due to their inertia, the solid particles can no longer follow the carrier jet. This causes a separation of the jet components which localizes the abrasion process. Material is removed at only a small section of the cutting flank.

- During the cutting process a step is created. The angle of deflection on the step increases constantly. There is increasingly less abrasion below the step. Less and less material is removed beneath the step.

- The step is ground out of the workpiece relatively quickly, until the colliding particles are no longer able to abrade the material. As the step moves downwards, a smooth front edge is created.

- The starting condition has been reached again.

During the cutting process, the abrasive water jet emerges from the bottom side of the workpiece with high remaining energy. This energy must be absorbed after cutting. The easiest way to do this is the with a water basin. The residual water jet energy is absorbed by a catcher travelling synchronous to the bridge. Abrasive water jet cutting is capable of producing high precision parts that usually requiring no further processing. Those parts which do require further processing are easier to machine and finish because the low operating temperature of the process does not produce the hardened edges or create structural changes in the workpiece. Almost any material can be cut. This even applies to very thick materials. As far as sheet metal processing is concerned, this greatly increases the range of thickness that can be processed. Abrasive water jet is cold slitting process. There is no thermal influence on the workpiece. This is particularly important when processing composite and coated materials. Abrasive water jet cutting produces very little lateral force, reducing or eliminating the need for fixturing to hold the workpiece. Toxic fumes, recast layers, slag and thermal stress are totally eliminated. Noise and flying dirt can be minimized by underwater cutting. Advantages of abrasive water jet cutting are: no thermal stress, no hardening, no workpiece tension, no dust or smoke build-up, no toxic fumes, smaller kerf width, very clean cut edges, high cutting speeds and accuracy, burr-free cuts, no post-machining, ideal for any cutting task. Disadvantages are: some materials can not be cut economically, and thick parts can not be cut with dimensional accuracy. Characteristics of abrasive water jet cutting are shown in table 1.

Table 1. Characteristics of abrasive water jet cutting

Energy medium	Water
Energy source	High-pressure pump
Energy transmission	Rigid high-pressure hoses
Material expulsion	High-pressure water jet
Typical beam output at workpiece	4 kW-17 kW (400 MPa)
General applications	Cutting, ablation, structuring
3D cutting	Only partly possible due to problem of destruction of residual energy behind the workpiece
Materials that can be cut	All materials
Material combinations	Possible but danger of delamination
Material properties which influence processing	Material hardness
Material thickness at which processing is economical	10-50 mm, depending on material
Most frequent applications	Cutting of ceramics, stone and metals
Minimum cutting slit	0.5 mm
Appearance of cut surfaces	Like sand-blasted, depending on cutting speed
Parallelism of cut edges	Good; "tailed" effect in curves in the case of thicker materials
Processing accuracy	Approximately 0.2 mm
Thermal stress of material	None
Forces acting on material in direction of jet	High; thin, small parts can thus only be processed to limited degree
Burring	No burring
Personal safety	Protective glasses, ear protection, protection against contact with abrasive water jet
Smoke and dust generation	Not applicable
Noise pollution	High
Cutting waste	Large quantities of cutting waste occur on account of mixing with abrasives
Wearing parts	Water nozzle, abrasive nozzle, high-pressure components (valves, hoses, seals)
Average consumption of complete system	20 kW pump; Electr. power: 22-35 kW; Water: 150 l/h; Abrasive: 36 kg/h; Disposal of cutting waste;

ABRASIVE WATER JET CUTTING MACHINES

Abrasive water jet cutting machines designed for a specific applications are

just as varied as the field of application. Concepts range from systems with fixed cutting head, machines equipped with an XY guided cutting head and robot guided cutting head. Machines designed in the form of a portal are used primarily in sheet metal processing. Abrasive water jet cutting machine with a portal construction combines high positioning precision with a very dynamic freedom of movement. The basic components of abrasive water jet cutting machine are: high pressure pump, high

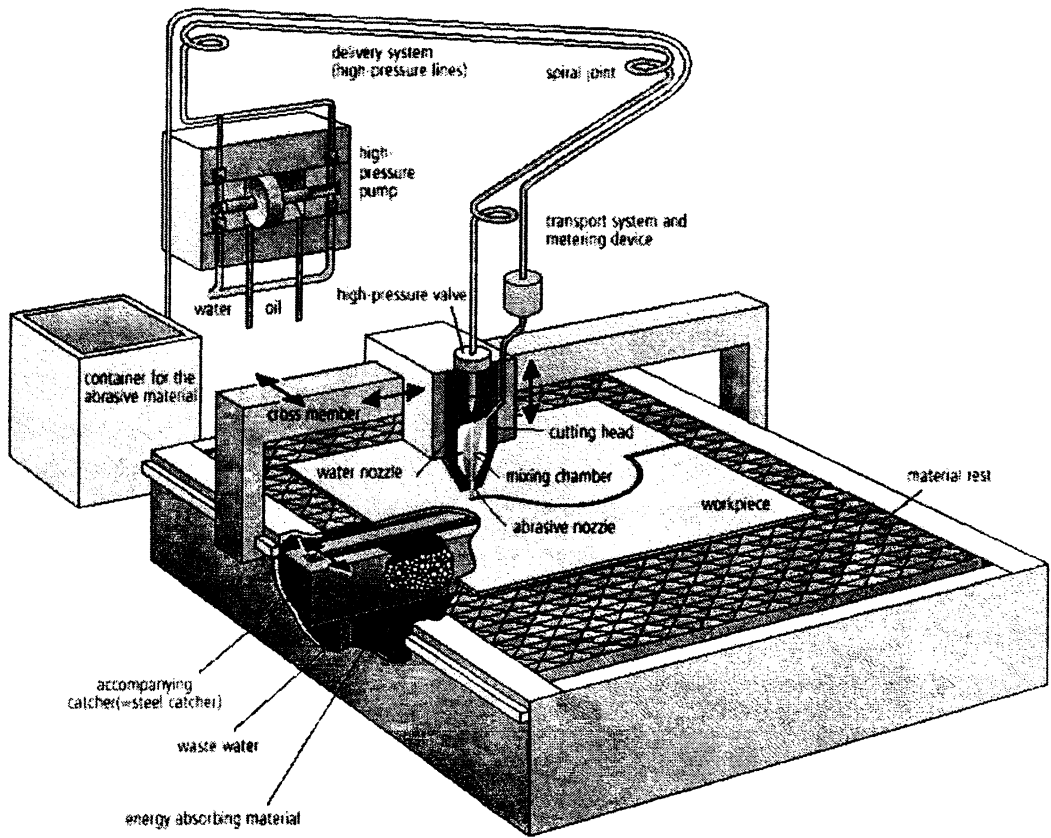

Figure 2. Abrasive water jet cutting machine

pressure delivery system, cutting head, storing, delivering and metering abrasive material, mechanical machine for movements, workpiece rest, catcher, disposal unit and control unit. In figure 2 is shown abrasive water jet cutting machine with a portal design.

The high pressure pump is the heart of a water jet machine. It creates the required operation pressure and transports the water through the system. The pressure pump for water jet cutting machine is high performance pump. It creates a pressure of up to 400 MPa. The back and forth motion of the pressure intensifier causes pressure fluctuations in the piston's end of a travel. For that reason, pumps for this pressure area are usually equipped with a pulsation damper to smooth out pressure fluctuations. The high pressure delivery system safely conducts the water under pressure from the pump to the cutting head. It consists of thick walled high pressure pipes

made of strain hardened austenite steel. The cutting head is the most important component of a water jet cutting machine. It consists from water nozzle, mixing chamber and abrasive nozzle. Water nozzle is made from a sapphire, ruby or diamond. Diameter of water nozzle is from 0.08 to 0.5 mm. Abrasive nozzle is made from hard metal. Abrasive nozzle is with diameter from 0.8 to 1.2 mm and length from 50 to 100 mm. Container for the abrasive material is located next to the machine. The abrasive material is transported from the container by means of a vacuum system to either the cutting head or to a metering device located on the cutting head. During processing, the workpiece lies on a rest. It is normally located directly on the machine frame. Depending on the machine concept, the workpiece is situated either above or below the water surface during processing. The catcher is filled with balls. It moves along with the cutting head and absorbs the remaining energy after the cutting process. Sludge (cutting chips and abrasive material residue) and waste water are separated in the disposal unit. Modern machines can hold tolerances of ± 0.1 mm or better. Automating the process with programmable systems in conjunction with the CNC control provides high flexibility and a wide variety of parts.

There are many manufacturers of abrasive water jet cutting machines. Industry leaders of manufacturers of abrasive water jet cutting machines are: Bystronic, ESAB, Ingersoll-Rand, OMAX Corp., TRUMPF GmbH, and WaterJet Sweden. In table 2 are shown some manufacturers of abrasive water jet cutting machines.

Table 2. Manufacturers of abrasive water jet cutting machines

Manufacturers	Web-site
Bystronic	www.bystronic.com
ESAB	www.esab.com
Ingersoll-Rand	www.irautomation.com/wjs
Jet Edge	www.jetedge.com
OMAX Corp.	www.onax.com
TRUMPF GmbH	www.trumpf.com
WaterJet Sweden	www.waterjets.org
Knuth	www.knuth.de

Pricing example of abrasive water jet cutting machine is 98.500 EUR for Hydro-jet 1010 (Knuth Werkzeugmaschinen GmbH, Germany).

CONCLUSION

Abrasive water jet cutting is an advance technology which can cut almost all engineering materials. It is capable of producing high precision parts that usually requiring no further processing. Those parts which do require further processing are easier to machine and finish because the low operating temperature of the process

does not produce the hardened edges. Abrasive water jet cutting produces very little lateral force, reducing or eliminating the need for fixturing to hold the workpiece. Toxic fumes, recast layers, edge hardening, slag and thermal stress are also totally eliminated. Application of abrasive water jet cutting increase the accuracy and the productivity.

Acknowledgement: Paper is result of technological project "Research of technological and economical parameters of manufacture the gears of big dimensions by nonconventional methods" which is supported by Ministry of Science and Environmental Protection of Republic of Serbia

REFERENCES

1. Kirkpatrick I., Continuous-path controlled water-jet cutting, Sheet metal industries, august, 1999, P. 413-414, 2. Konig W., Wulf Ch., Wasserstrahlschneiden, Industrie anzeiger, Nr. 92 v. 16. 11. 1984/106. Jg. P. 35-38, 3. Oweinah H., Leistungssteigerung des hochgeschwindigkeits - wasserstahlschneidens durch zugabe von abrasivstoffen (abrasiv-jet), Industrie anzeiger, Nr 34v. 29.4.1986/108, pp. 30-31, 4. Eichorn F., Autogen-, plasma- und wasserstrahl-verfahren, Inovative schneidtechnologien, Industrie anzeiger, august, 1999, pp. 413-414, 5. Deaconescu T., Deaconescu A., Aspects regarding abrasive jet cutting, Conference "Situation and perspective of research and development in chemical and mechanical industry", Krusevac, Yugoslavie, 2001, pp. 82-86, 6. Olsen J., Buying an abrasive jet machine, The Fabricator, April 15, 2002, 7. Olsen J., Not your father's abrasive jet, The Fabricator, July 12, 2001, 8. Radovanovic M., Precision cutting by abrasive waterjet, Scientific conference with international participation "Manufacturing and management in 21st Century", Ohrid, Republic of Macedonia, 2004, pp. 94-99, 9. Jankovic P., Radovanovic M., Vicovac N., Essential components of abrasive water jet cutting machines, Scientific conference with international participation "Manufacturing and management in 21st Century", Ohrid, Republic of Macedonia, 2004, pp. 100-105, 10. Radovanovic M., Comparison of advanced machining processes for contour cutting of plate, International conference "Computing and solutions in manufacturing Engineering CoSME '04", Brasov, Romania, 2004, pp. 437-442, 11. Radovanovic M., Comparison of abrasive water jet cutting and plasma cutting, International scientific conference Unitech'04, Gabrovo, Bulgaria, 2004, pp. II-137-II-142.