

EXPERIMENTAL INVESTIGATION OF TRUCK TRACTOR'S BRAKE SYSTEM EFFICIENCY EQUIPED WITH DISC BRAKES

Dzmitry Tretsiak

Belarussian National Technical University

Keywords: brake system, disc brake, self-boosting, efficiency.

Introduction

Annually 1,2 million person perish and about 50 million traumatize in traffic accidents in the world by Worldwide Health Organization estimations. 2-3 m of a brake distance falls short to prevent 70 % of traffic accidents on the average. Forecasts show that value of traffic accidents sacrifices will increase approximately by 65 % for the next 20 years if this problem will not be solved. The general costs are assessed at 518 billion US dollars per year from traffic accidents and traumatism in the world [1]. In Russian Federation for 2007 an accident rate statistics shows that to 70 % of traffic accidents is made at driver's application in emergency braking mode and to 60 % is accompanied by loss of stability and controllability [2].

Therefore, safe vehicles creation is one of the major problems facing the auto makers. Effective braking maintenance is one of determining factors of vehicle safety. And it's a subject of in-depth scientific investigations throughout many years. Thus, this problem should be considered in close interrelation with other vehicle characteristics, such as stability and ergonomics.

Investigations to enhance the efficiency of different brake system components and efficiency of the whole brake system are crucial for automotive manufacturers. The special emphasis is placed in this area to the brake mechanisms. The most important brake system components are wheel brake mechanisms while namely they transform a control effort from a brake drive into a brake torque which is applied to a wheel. Brake mechanisms are one of the most complicated vehicle units in respect to a mathematical description of the processes which are take place in them during a braking [3, стр. 139]. Disc and drum brakes are widespread on modern vehicles.

Based on detailed review of scientific works connected with the perspective disc brake designs [4-7], it can be concluded that one of the best variants to improve disc brakes efficiency is connected with self-boosting principles. Almost all known disc brake designs with self-boosting use so-called "Wedge principle" to obtain this effect [8]. In general, it means that there is a wedge element between the pad and frame which clamps the pad with friction lining to the brake disc. However, unstable behavior probability of such a brake is high enough in working conditions [7]. To prevent this negative effect, it is necessary to secure a wedge pinpoint positioning. That increases requirements to accuracy of brake elements production and demands development of control algorithms with a high-rapid rate. As a result the brake cost essentially increases.

Thus, the design of disc brake with self-boosting was developed which demands minimal changes in comparison with a serial disc brake. Author has patents of Republic of Belarus on this disc brake design [9-10].

Design of disc brake with self-boosting

Proposed design of disc brake with self-boosting which contains support 1, brake disc 2, brake pads 3 with friction linings 4 and caliper 5 is different in that it has additional elements - intensifying plugs 5 which are connected with brake pads 3 and supported on the support 1 (figure 1). Injection of intensifying plugs allows automatically increase a brake torque value during a braking.

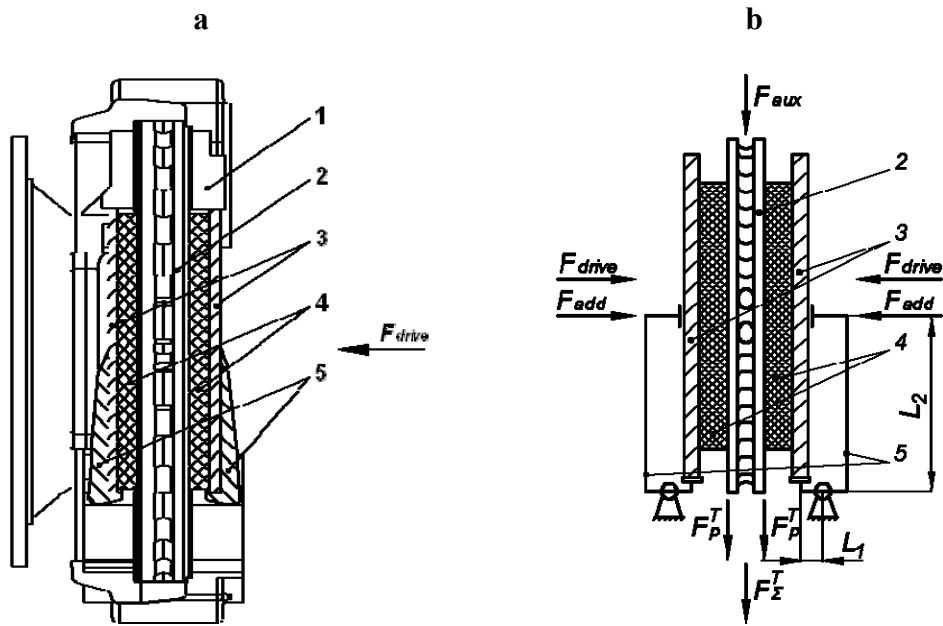

Figure 1: Scheme of disc brake with self-boosting:

a – arrangement of disc brake with self-boosting;

b – scheme of load applying in disc brake with self-boosting;

1 – support; 2 – brake disc; 3 – brake pads; 4 – friction linings; 5 – intensifying plugs;

F_{aux} – axial force; F_{drive} – brake drive effort; F_{add} – additional force because of self-boosting effect; F_p^T – friction force of one pad; F_Σ^T – total friction force; L_1, L_2 – intensifying plugs sizes

Work of the brake based that there is a friction force in the contact zone between brake disc 2 and friction linings 4 of brake pads 3 which aspires to move pads in the direction of a brake disc rotation, figure 1. Then this effort is in addition applied to brake pads because of intensifying plugs 5, that automatically increases a driving effort value F_{drive} .

Let's consider a disc brake with self-boosting work which functional scheme is presented on figure 2, a. According to this scheme a disc brake is an control object which output parameter is a brake torque. Brake pads and intensifying plugs are included at negative feedback in disc brake with self-boosting, and the part of normal effort, acting from brake disc to pads, transforms with amplifying coefficient because of intensifying plugs to a forces which clamp brake pads to disc. Then these additional efforts are summarized with clamping force from a brake drive.

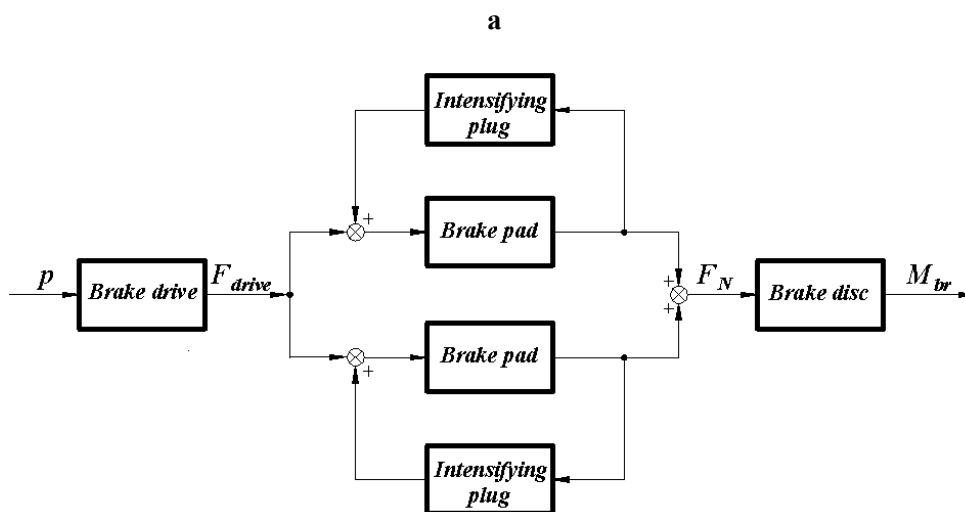

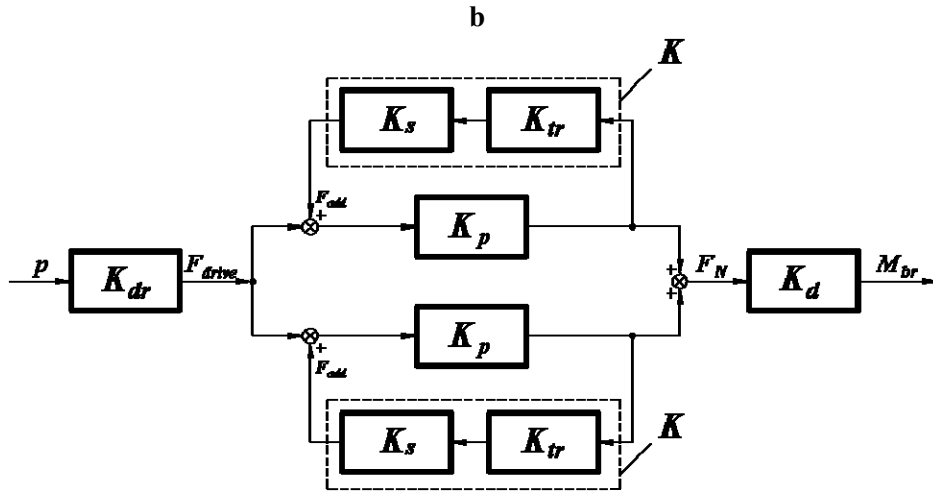

Figure 2 – Functional and structural scheme of disc brake with self-boasting:

p – pressure in a brake system during a braking; F_N – reaction force from brake disc;
 M_{br} – brake torque; K – conversion coefficient of positive feedback; K_d – conversion coefficient of normal force from brake pads F_N into brake torque M_{br} ; K_{dr} – conversion coefficient of brake drive pressure into brake drive force; K_p – conversion coefficient of brake system pressure into normal clamping force; K_{tr} – conversion coefficient of brake torque acting on a brake pad into clamping force which clamps it to brake disc; K_s – amplifying coefficient of intensifying plugs; F_{add} – additional effort because of self-boasting effect

The structural scheme of disc brake with self-boasting was developed on the base of its functional scheme. Converting properties of system elements are determined thru the ratio of output signal to input signal [11].

Thus, brake torque of disc brake with self-boasting is determined:

$$M_{br} = \frac{2 \cdot F_{drive} \cdot \mu \cdot r_{\mu}}{1 - K_s \cdot \mu}, \quad (1)$$

where μ – friction coefficient in the contact between brake pads and brake disc;
 r_{μ} – friction radius.

As we have mentioned, a disc brake with self-boasting is a system with positive feedback in accordance to a brake drive force. Consequently, the self-boasting value should be in order to exclude jamming the brake and blocking a wheel. Wheel blocking may take place when a brake torque, created by a wheel brake, exceeds a friction torque in the contact between wheel and road surface:

$$M_{br} < M_{\varphi}, \quad (2)$$

where M_{φ} – adhesion torque of wheels.

In that case

$$K_s < \frac{1}{\mu} \left[1 - \frac{2 \cdot F_{drive} \cdot \mu \cdot r_{\mu}}{R_z \cdot \varphi \cdot r_0} \right] \quad (3)$$

where φ – friction coefficient in the contact between road surface and tire;
 r_0 – wheel rolling radius.

Thus, the demanded value of amplifying coefficient is determined under condition of wheels blocking absence proceeding from values of entrance parameters for concrete vehicle.

Experimental investigation of brake system efficiency

Experimental investigation of air-operated brake system efficiency for truck tractor (analogue MAZ-544008-060-030 produced at Minsk Automobile Plant) was carried out to check the efficiency of proposed design of disc brake with self-boosting.

Technical data of truck tractor MAZ-544008-060-030 are presented in table 1 [12].

The critical amplifying coefficient value of disc brake with self-boosting for choused truck tractor was calculated. It was conclude that amplifying coefficient value should be less than 1,48. Accordingly, sizes of intensifying plugs, support, caliper and a whole disc brake can reach substantial values at constitutive value of amplifying coefficient. This in turn will have a negative influence on disc brake hysteresis and response time [13]. Furthermore, increasing of disc brake mass and sizes can negative influence on unsprung masses value and, consequently, on vehicle controllability and smoothness.

Also a big disc brake sizes make a higher demands to general arrangement. Because it can lead to necessity to change an axle beam design that essentially increases these units cost.

Table 1: Technical data of truck tractor MAZ-544008-060-030

Parameter	Value
Wheel arrangement	4x2
Fully loaded vehicle mass, kg	18750
Fully loaded mass on front axel, kg	7250
Fully loaded mass on rear axel, kg	11500
Laden vehicle mass, kg	8050
Overall height, mm	4000
Overall length, mm	6000
Wheelbase, mm	3600
Engine	YMZ-7511
Engine power, kw (p.h.)	294 (400)
Maximal engine torque, Nm	1715
Gearbox	ZF 16S1650
Number of gears	14
Drive axle ratio	3,86
Wheel size	315/80R22,5
Ecological safety	Евро-2
Maximal speed, km/h	100

From the analysis of front axle arrangement it was conclude that there is no significant increasing of masses and sizes of caliper and support of disc brake under the condition that amplifying coefficient of intensifying plugs doesn't exceeds 0,25. Thus, the design study for intensifying plugs, support and caliper was lead under the condition that the amplifying coefficient is equal 0,23.

It was proposed to analyze the influence of self-boosting effect on brake system efficiency with help of brake system efficiency dependence against air pressure in brake chambers. A brake torque of disc brake with self-boosting is calculated in accordance to (1) and it can be represented like:

$$M_{br} = 2 \cdot K \cdot F_{drive} \cdot \mu \cdot r_{\mu}, \quad (4)$$

where K – amplifying coefficient of disc brake.

$$K = \frac{1}{1 - K_s \cdot \mu} \quad (5)$$

Ride tests were carried out on laden truck tractor without semitrailer. The reason is that it's necessary to exclude the influence of inertial force from semitrailer on a truck tractor during a braking for sufficient estimation of brake system efficiency in dependence of a brake drive pressure.

Brake system efficiency of a truck trailer was estimated in accordance with Regulations №13 EEC UNO [14] during a braking from initial speed 60 km/h on a dry cleanly asphalt surface till full stop (tests of type 0). A pressure from brake drive was changed from 0,1 to 0,9 MPa to obtain a brake system efficiency dependence against air pressure in brake chambers.

Average value of vehicle limiting deceleration is calculated like [14, c. 87]

$$d_m = \frac{v_b^2 - v_e^2}{25,92 \cdot (s_e - s_b)}, \quad (6)$$

where v_0 – initial vehicle speed during the braking, km/h;

v_b – vehicle speed at $0,8v_0$, km/h;

v_e – vehicle speed at $0,1v_0$, km/h;

s_b – distance which is passed between v_0 and v_b , m;

s_e – distance which is passed between v_0 и v_e , m.

To control and supply strongly defined air pressure value in brake chambers there were some modifications in brake system of truck tractor. The two-main valves were installed into brake pipes which deliver the air pressure to the wheel brakes of front and rear axle. From an air tank the pressure derives to two-main valves through electromagnetic solenoids. Also manometers were attached to brake pressure control valve with the purpose to control the pressure value which is deliver to brake chambers of wheel brakes on front and rear axles.

Next control equipment was used during carrying out of ride tests (figure 3):

- A set of instruments to measure the parameters of vehicle movement "Peiseler" VTS-WB III;
- Manometers to measure air pressure in a brake circuits with precision of measurements $\pm 0,5$ %.

Measurements precision of vehicle speed and braking distance is $\pm 0,5$ %.

Thus, an average quadratic deviation is less than 0,9 % during ride tests with help of such control equipment.

Table 2 contains values of vehicle brake distance and deceleration which was calculated with help of (6) during the braking (tests of type 0) and different air pressure values in braking circuits of front and rear wheel brakes.

According to Regulations №13 EEC UNO the braking distance of test vehicle (N_3 category) should be less than 36,7 m and average value of vehicle limiting deceleration – less than 5 m/s².

After experimental data handling (table 2) it was estimated that average value of vehicle braking distance at tests of type 0 is 27,1 m and limiting deceleration – 5,48 m/s². The difference between air pressure in braking circuits of front and rear wheel brakes is explained that there is a brake force regulator in vehicle brake system.

a

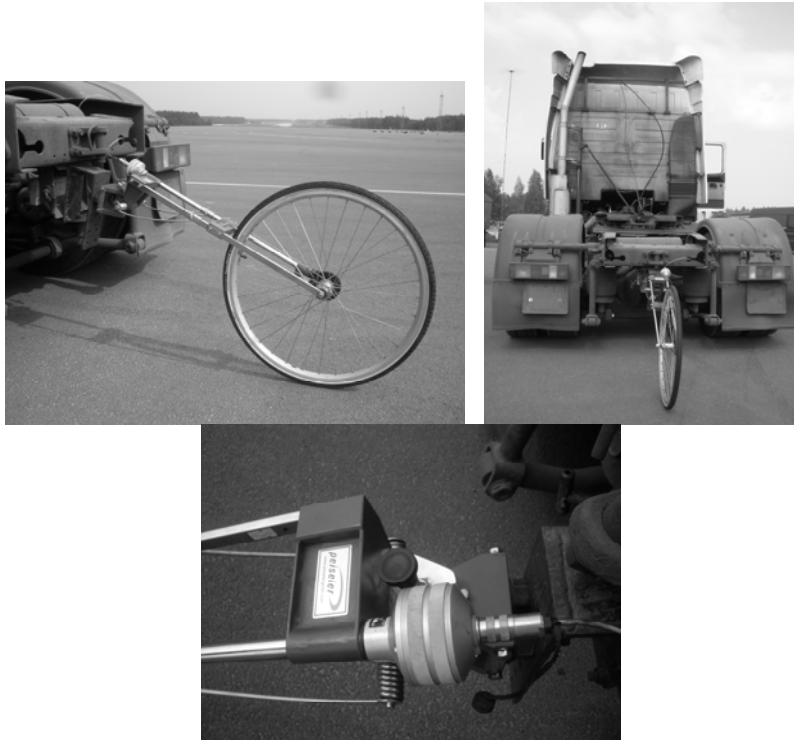

b

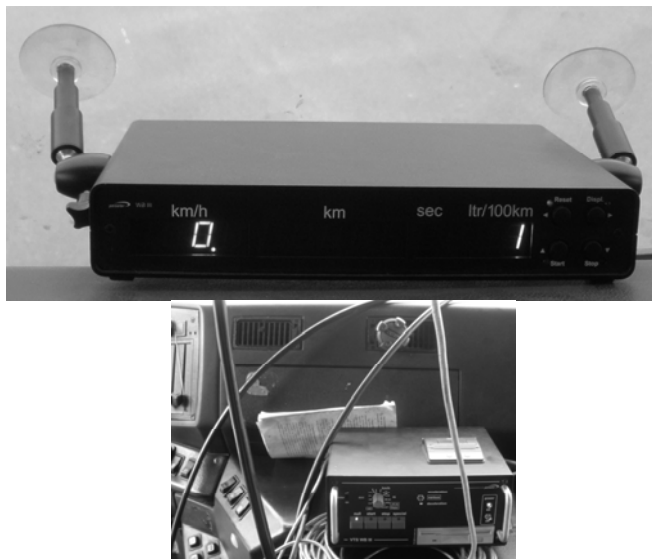

c



d



Figure 3: Measuring instruments:
a – "fifth" wheel "Peiseler"; **b** – electronic speedometer and detector "Peiseler";
c – block of electromagnetic solenoids; **d** – manometers

Consequently, it was concluded that brake system efficiency of test vehicle satisfy to requirements of Regulations №13 EEC UNO.

Table 2 – Parameters of brake system efficiency of MAZ-544008-060-030

Air pressure at braking circuit of front wheel brakes, MPa	Air pressure at braking circuit of rear wheel brakes, MPa	Deceleration, m/s ²	Braking distance, m
0,1	0,06	0,88	95
0,1	0,06	0,81	98,3
0,2	0,1	2,02	74,9
0,2	0,1	2,02	75,7
0,28	0,145	2,99	63,8
0,3	0,145	3,05	60,7
0,4	0,18	3,84	49,1
0,4	0,175	3,8	49,5
0,5	0,23	4,61	38,4
0,5	0,22	4,61	38,3
0,6	0,27	4,89	30,3
0,6	0,25	4,94	30,1
0,635	0,28	4,97	30,7
0,64	0,28	5,09	28,5
0,7	0,3	5,38	27,0
0,7	0,31	5,39	26,9
0,75	0,28	5,49	26,1
0,75	0,28	5,48	26,0
0,8	0,34	5,55	25,9
0,8	0,34	5,56	25,8
0,85	0,36	5,54	26,5
0,85	0,37	5,53	26,4
0,9	0,38	5,5	27,8
0,9	0,38	5,51	27,7

According to experimental data the analytical dependences (figure 4) of vehicle braking distance and acceleration against air pressure at braking circuit of front wheel brakes with confidence interval of 98 % were obtained using least-squares method with help of STATISTICA software. Also the correlation coefficient was calculated for these dependences (table 3).

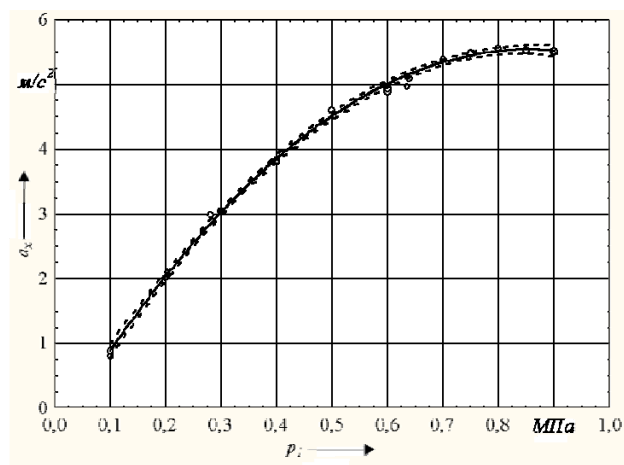

a

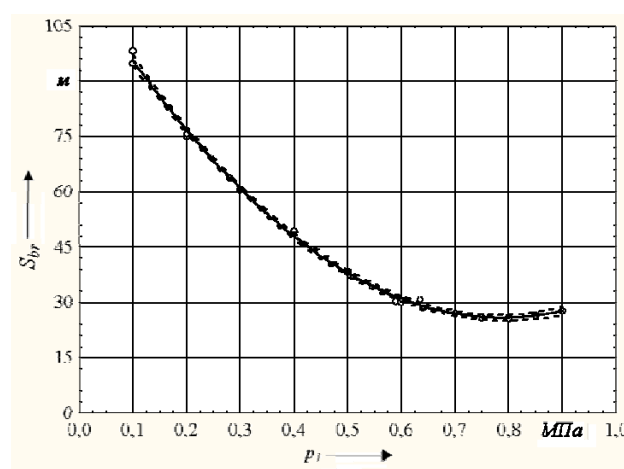

b

**Figure 4 :Dependences for parameters of brake system efficiency against air pressure at braking circuit of front wheel brakes:
a – deceleration; b – braking distance**

Table 3 – Analytical dependences and correlation coefficients

Parameter of brake system efficiency	Analytical dependence	Correlation coefficient
Braking distance, m	$S_{br} = 148,2 \cdot p_1^2 - 233,3 \cdot p_1 + 117,6$	0,93
Deceleration, m/s ²	$a_x = -8,2 \cdot p_1^2 + 14,0 \cdot p_1 - 0,4$	0,95

It's possible to estimate a total force from a brake drive with knowledge of amplifying coefficient value and conversion coefficient of positive feedback (5). This effort can be translate to the air pressure value at braking circuit of front wheel brakes. After that with help of analytical dependences (table 3) it was forecasted enhancement of brake system efficiency under the condition that it equipped with disc brakes with self-boosting. Table 4 contains deceleration and braking distance values which was obtained during ride tests like type 0 [17]. It was taken into account that maximal air pressure in brake chambers of serial brake system during emergency braking is 0,7 MPa according to data from Design manager department of Minsk Automobile Plant.

Table 4: Parameters of brake system efficiency MAZ-544008-030-020

Parameter of brake system efficiency	Serial disc brake	Disc brake with self-boosting	Enhancement, %
Braking distance, m	27,0	25,8	4,4
Deceleration, m/s ²	5,39	5,52	2,4

Consequently, it has been found experimentally that the efficiency of brake system with disc brakes with self-boosting is enhanced sufficiently: deceleration value is increased on 2,4 % and braking distance is decreased on 4,1 % or 1,1 m.

Conclusion

As a result of carrying out investigations and ride tests the possibility to create disc brakes design with minimal hysteresis and high-rapid rate, accordingly, was theoretically founded and experimentally confirmed. It's reached by entering the positive feedback in disc brake design which is supplied a self-boosting effect.

Analytical dependences of vehicle braking distance and acceleration against air pressure at braking circuit were obtained.

Efficiency of brake system with disc brakes with self-boosting is enhanced: deceleration value is increased on 2,4 % and braking distance is decreased on 4,1 % or 1,1 m.

Enhancement of brake system efficiency with disc brakes with self-boosting can be vastly more, while the hysteresis losses value of such disc brake design is significant lower [13]. Consequently, a phase of retention interval in ABS control algorithm can be reduced proportionally to hysteresis reducing. As a result, response time of disc brake with self-boosting is decreased.

References

1. Coelingh, E. Collision warning with auto brake – a real-life safety perspective / E. Coelingh [and others] // Proc. of 20th Enhanced Safety of Vehicle Conference. № 07-0450. – Lyon, France. – 2007. – 9 pp.
2. Alonso, V.F. Enhancement of strengthening calculation methodology of front suspension unit for the vehicle with ABS: abstract of Doctoral work. / V.F. Alonso; Volgograd State Technical University. – Volgograd, 2008. – 16 pp. (in Russian).
3. Revin, A.A. Theory of vehicle operating ability with ABS during a braking: Monograph / A.A. Revin. – Volgograd: "Polytechnic", 2002. – 172 p. (in Russian).
4. Device for actuating disk brakes in motorvehicles or elsewhere: patent EP0141409A1 European Patent Office / S. Collini; applicant Silvano, Collini. – Application number 84113189.9; date of filing 02.11.84; publication date of application 15.05.85 Bulletin 85/20 // European Patent Office. – 1985. – 14 pp.
5. Balogh, L. Modelling and simulating of self-energizing brake system / L. Balogh [and others] // Vehicle System Dynamics. International Journal of Vehicle Mechanics and Mobility. – 2006. – Vol. 44, Supplement. – P. 368-377.
6. Knorr-Bremse ABS-Bremssystem für Motorfahrzeuge 4S/4M: report / Knorr-Bremse. – Lehrtafeln, 2004. – 1 p. № P-3918-DE-0002.
7. Hartmann, H. eBrake® – the mechatronic wedge brake / H. Hartmann [and others] // SAE Technical paper series. № 2002-01-2582. – Warrendale: SAE, 2002 – 6 pp.

8. Limpert, R. Brake Design and Safety. Second Edition / R. Limpert. – Warrandale: Society of Automotive Engineers Inc., 1999. – 538 p.
9. Disc brake: patent 3799 Rep. of Belarus, МПК7 C 08 J 5/20, C 08 G 2/30 / D.V. Tretsiak, A.I. Bandarchuk, S.V. Kliuzovich, V.G. Ivanov, B.N. Shyrokau; design applicant Д.В. D.V. Tretsiak, A.I. Bandarchuk. – № a 0000011; declaration. 12.02.07; publication 30.08.2007 // Official bulletin / National Center of Intellectual Property. – 2007. – № 2. – P. 174.
10. Disc brake: patent 12441 Rep. of Belarus, МПК(2006) F16D 55/22, B60T 8/54 / D.V. Tretsiak, A.I. Bandarchuk, S.V. Kliuzovich, V.G. Ivanov; design applicant D.V. Tretsiak, A.I. Bandarchuk. – № a 20060867; declaration. 30.08.06; publication 30.11.2009 // Official bulletin / National Center of Intellectual Property. – 2009. – № 5. – P. 127.
11. Pervozvansky A.A. Theory coarse of automatic control: school-book: / A.A. Pervozvansky. – M.: Science, 1968. – 616 c. (in Russian).
12. MAZ 544008-060-030 // Minsk Automobile Plant [Internet resource]. – 2010. – Access mode: http://maz.by/_oid7494.html – Date of access: 18.08.2010.
13. Tretsiak, D. Investigation on Hysteresis Losses into Disc Brake Gear for Heavy Vehicles / D. Tretsiak, V. Ivanov // SAE Technical Paper Series. No. 2006-01-3212. – Warrendale: SAE, 2006. – 7 pp.
14. Regulations №13 EEC UNO. – Geneva, 1996. – №3. – 184 pp.